

SNMG150616RP KCM15B

Produktnummer: 5641107

SNMG150616RPKCM15B

ISO WENDEPLATTEN DREHEN SN..



Spesifikasjoner Kennametal

Vekt	0.0197 kg
Bredde/tykkelse	0 mm
Høyde	0 mm
Volum	0.02 liter
TypeW	N/A
Dimensjon	0
Nøkkelvidde	0 mm
Form	SNMG
Drivtype	N/A
Batterispenning	N/A
Kategori/IP/digital	N/A
kW	0
Modul/profil	N/A
Tanning	N/A
Innvendig diameter	0 mm
Utvendig diameter	0 mm
Type	N/A
Type 4	0
Lengde X dia	N/A

Delelengde	0 mm
Type 3	0
Serie	N/A
Metrisk/tomme	N/A
Kvalitet	N/A
Tekst	N/A
Materiale	N/A
Bredde ytre ring	0 mm
Bredde indre ring	0 mm
Korning	N/A
Type 2	0
Type 5	0
Type 7	N/A
Bordiameter	0 mm
Bortype	N/A
Borelengde	N/A
Diameter	0 mm
Neseradius	1.6 mm
Størrelse	15
Lengde	0 mm
Antall tenner/rader/deling/spor	N/A
Bruksområde	N/A
Tange/hull	N/A
S	jun.00
Kvalitet	KCM15B
Y	5.000
D1	jun.00
Pakke Størrelse	5
Beskrivelse	ANSI/ISO Turning Insert SN..
aN	0.000
Material Andre Grupper	Steel,High-Temp Alloys
L10	15.8750
Platform	Kenloc
R	jan.00
Material Hoved Grupper	Stainless Steel
Varekode	SNMG150616RP
Maks omd.	S-Square 90

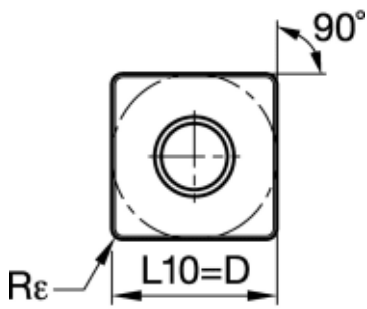

Les mer om produktet her:

<https://www.ail.no/product?number=5641107>