

ROTALIGN® smart EX

The ultimate intrinsically safe alignment system

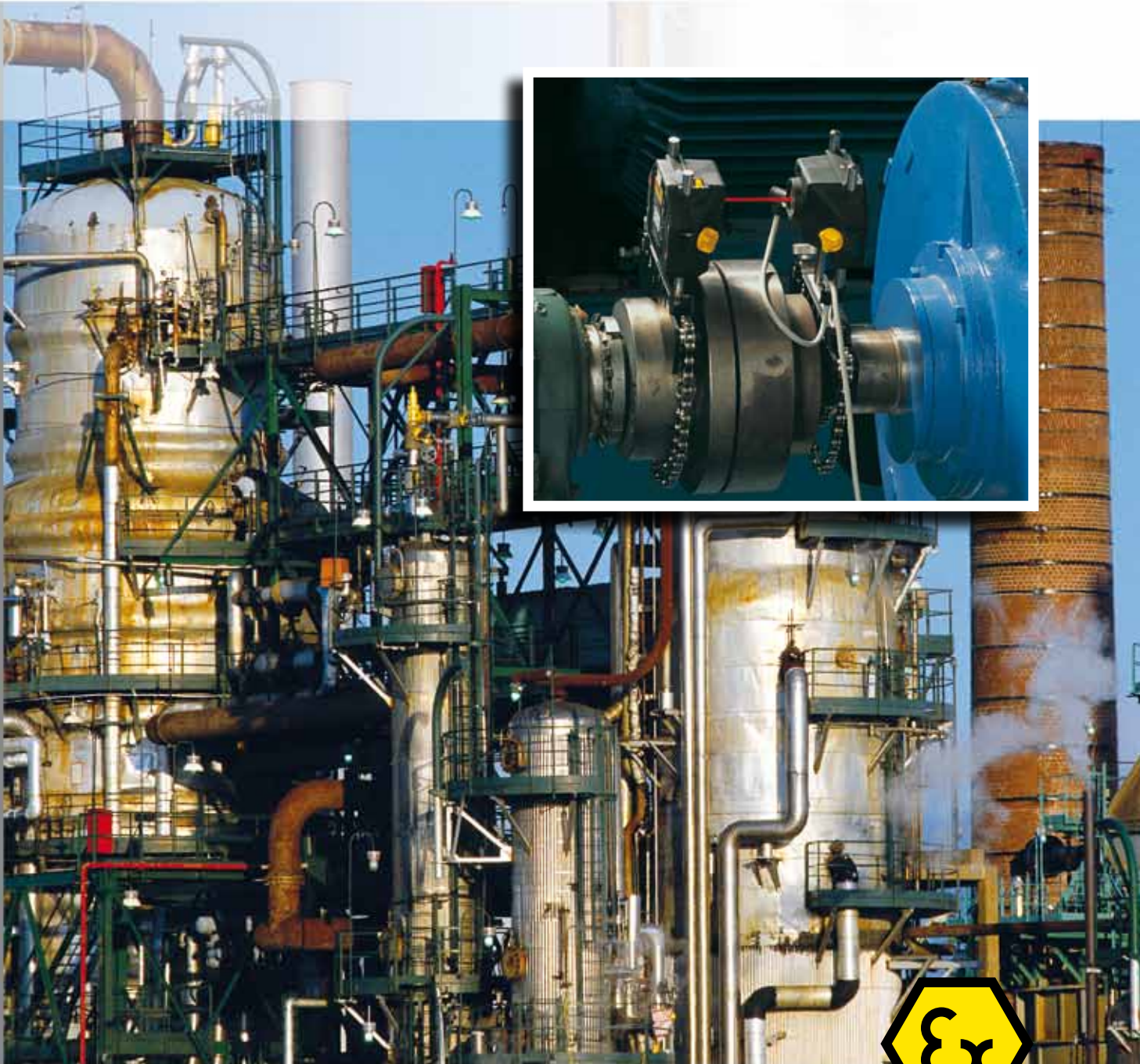

ROTALIGN® smart EX

ROTALIGN® smart EX is a high-end laser shaft alignment system designed for the use in potentially explosive atmospheres. The package integrates the OPTALIGN® smart EX computer packed with powerful capabilities and the unique benefits of the 5-axis ROTALIGN® EX sensor measurement technology.

ROTALIGN® smart EX is manufactured for use in hazardous areas in accordance with ATEX and IECEx regulations.



Highlights

- | | |
|----------------------------------------------------------------------------------------------------------|---------------------------------------------------------------------------------------------|
| Alignment of coupled and uncoupled shafts | TolChek® – automatic evaluation of alignment condition and user defined tolerances |
| Alignment of horizontal, vertical and flanged mounted machines | Fixed feet selection resolves base-bound and bolt-bound problems |
| Alignment of cardan and spacer shafts | Realistic machine graphics |
| Live monitoring of horizontal and vertical corrections concurrently | High memory capacity and data protection capability |
| UniBeam® – single laser beam technology | Protected against dust, water, and grease in compliance with classification IP 65 and IP 67 |
| Variety of measurement modes to suit any application: Continuous Sweep, Static, Multipoint and Pass mode | High resolution backlit colour TFT screen |
| Machine train alignment for up to 6 machines | USB interface for PC and printer |
| Soft foot measurement with sensor at any angular position | Rigid pre-assembled universal brackets and additional support posts included |
| Unlimited detector range, no limitation on the detector measurement area | ALIGNMENT REPORTER freeware for file backup and printing reports |



Unique capabilities

LIVE move

The ROTALIGN® measurement technology allows machine corrections to be monitored concurrently in both horizontal and vertical planes with the laser and sensor mounted at any angular position. This capability is extremely useful in case of limited access to predetermined positions.

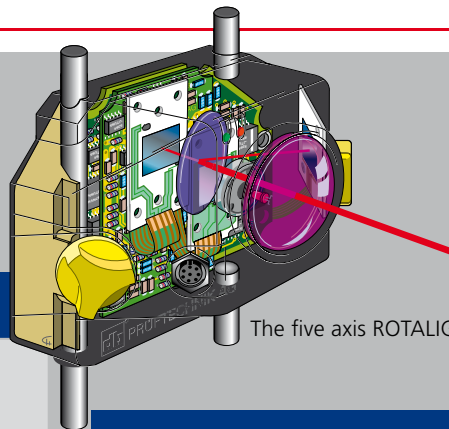

The five axis ROTALIGN® EX sensor

Pass measurement mode

The ROTALIGN® EX sensor allows the exceptional and convenient Pass measurement mode, where readings are collected when the laser passes the sensor. This mode is ideal for measurement of uncoupled shafts.

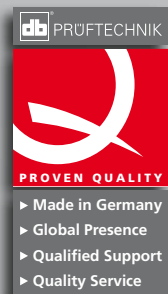

PRUFTECHNIK
Alignment Systems GmbH
Freisinger Str. 34
85737 Ismaning, Germany
Tel. +49 89 99616-0
Fax. +49 89 99616-100
info@pruftechnik.com
www.pruftechnik.com